

PMC Drawing Number:SR-030-□□□□□

1. Material: 30P PVC, UL94V-2, DEHP, DINP is less than 0.1%.
2. Color Available: RD=Red, OR=Orange, YL=Yellow, GN=Green, BL=Blue, PU=Purple, BK=Black, GY=Gray, WH=White, CR=Clear
3. Inner Diameter Available :5.0mm=50, 5.5mm=55
4. Packaging Quantity: ⊙=1000pcs, ⊕=500pcs, ⊗=250pcs, ⊖= 200pcs, ⊘=100pcs, ⊗= 50pcs, ⊙= 25pcs, ⊚= 10pcs

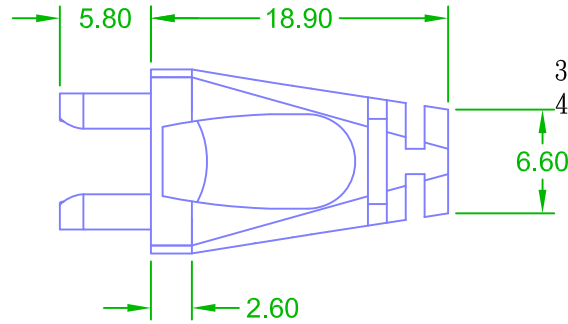

SR-030-□□□□□  
 Packaging Quantity(S, T, U, V, W, X, Y, Z)  
 Inner Diameter:(50, 55)  
 Color (RD, OR, YL, GN, BL, PU, BK, GY, WH, CR)

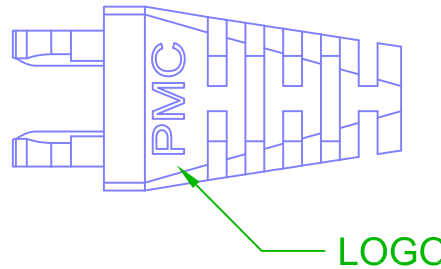
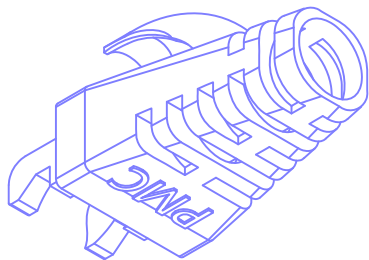
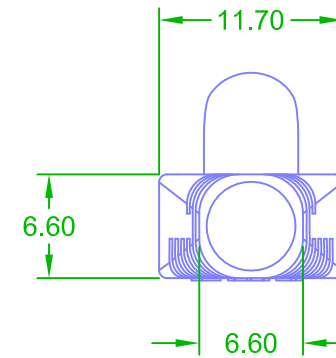
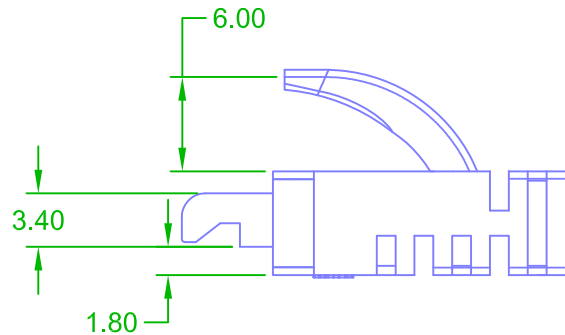
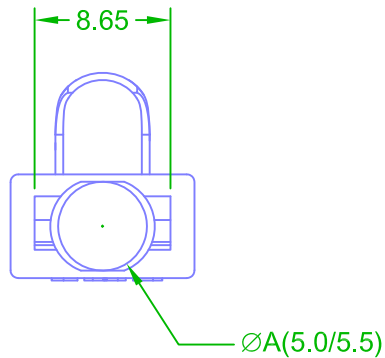

NOTE TOL:±0.15

B	2018.09.17. Rescheduling coding	3RD	⊕	Drawing	Chidy	Date	2013/04/23	Part.NO	SR-030
A	An initial version	Unit	m/m	Checked	Chris	Date	2013/04/23	Description	
Rev	Description	Scale	1:1	Approved	Jason	Date	2013/04/23	S8P-F型用 OD:5.0/5.5 Plug Boot	



**Plug Master**  
 INDUSTRIAL CO., LTD  
 www.plugmaster.com.tw